



Operation manual



6.9752.0003

ECO IR 3

Infrared dryer

Content

1. Precaution	1
2. Technical specifications	2
3. Control panel	3
4. Installation	4
5. Operation	5
6. Trouble shooting	6
7. Light tubes exchange	7
8. Circuit diagram	8

1. Precaution

1. Read this manual carefully before installing or using the device.
2. Before first use, check / unscrew connections of the fluorescent tubes. If the screw connection is too strong, the arc tube will break due to temperature induced expansion.
3. Attention! Device becomes hot, risk of injury and fire!
4. This device is intended for paint drying applications. Set the correct temperature and keep the minimum safe distance from the heat source during operation. Improper use can lead to surface damage.
5. Installation and maintenance must be performed by a qualified installer or service company.
6. The system is designed for easy installation, low operating costs and minimal maintenance. The warranty does not cover damage to the fluorescent tube caused by incorrect handling or incorrect operation.
7. The warranty does not cover damage caused by improper use.
8. Disconnect the power source when the unit is not going to be used for a long time.
9. The tubes should not be perpendicular to the ground when the device is turned on. Otherwise, the life of the arc tube is shortened.
10. Before use, make sure the cartridge connector is firmly connected.

2. Technical specifications

Model	ECO IRE3
Input voltage	230V 50/60Hz Single phase
Total power	3 x 1100W
Curing area	1200 x 1000mm
Temperature	40°C - 100°C adjustable
Timer	0 Min – 99 Min adjustable
Light intensity	10%-100%

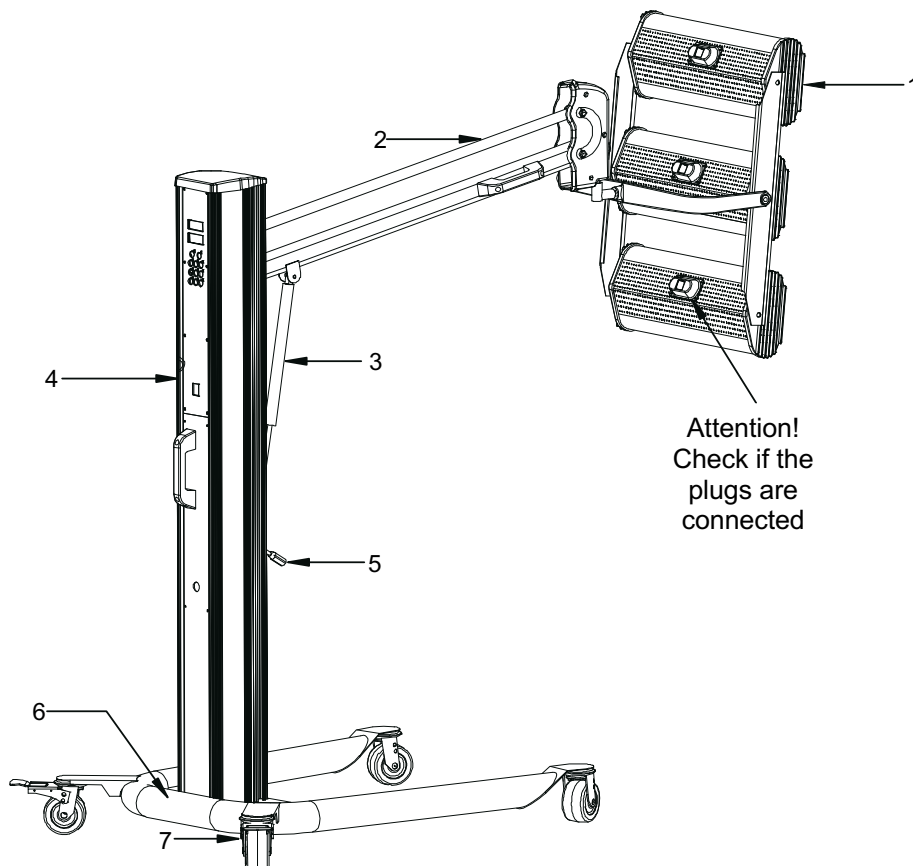

1. Cassette
2. Support arm
3. Lifter / damper
4. Column
5. Lifting handle
6. Substructur
7. Roll / brakes

3. Control panel

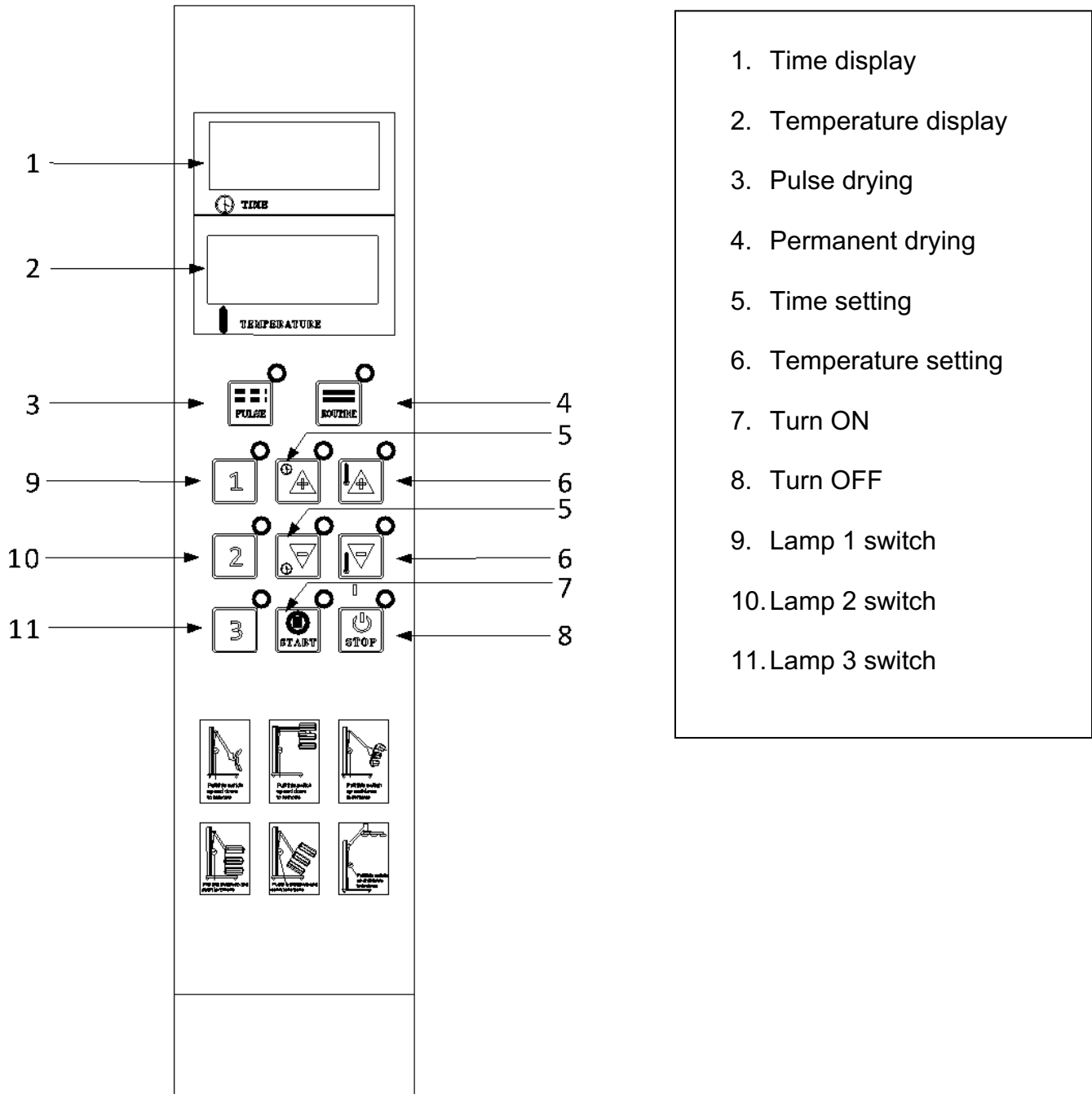

4. Installation

1. Installation of the substructure:

- a. Remove the substructure from the packaging.
- b. Place the substructure on the ground.
- c. Attach the four wheels to the base and tighten the screws.
- d. Make sure the rollers with brakes are mounted on the back of the substructure.

2. Installation of the column:

- a. Remove the column from the packaging.
- b. Place the column vertically on the base and screw it together.
- c. Connect the support arm with the column.
- d. Connect the lifter / damper with the column and the support arm to control the up and down movement of the support arm.

Installation of the lamp bracket:

- a. Remove the lamp bracket from the packaging.
- b. Screw the lamp bracket to the support arm.
- c. Connect the control cables and adjust the angle of the lamp bracket.

Further information can be found on page 2.

5. Operation

1. Connect the electricity. The supply cable must be at least 4mm² at 230V.
Make sure the supply voltage and frequency are as specified correspond to the type plate of the device.
2. Switch on the device, symbols are displayed.
3. Set the distance between the device and the workpiece. Usually a distance of 30 – 60 cm is to be kept.
4. Select drying mode. (Pulse drying achieves a better gloss)
5. Set time and temperature according to the manufacturer's specifications of the applied materials to achieve the desired result .

Watch out! Device heats up during use. Injury and fire hazard!

Switch off the appliance after use. Store the device in a safe place to avoid damage.

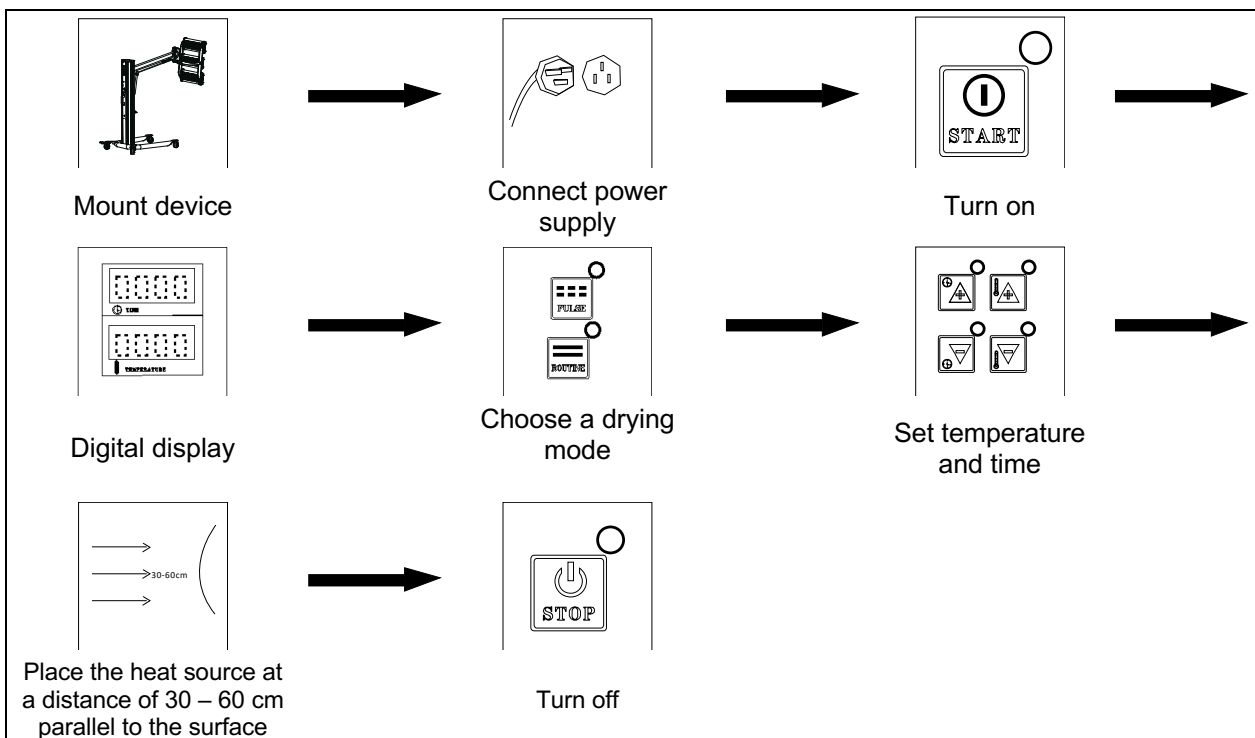

6. Trouble shooting

Error	Reason	Solution
Light tube doesn't work	<ul style="list-style-type: none"> • Light tube defective • Not connected • SRC defective 	<ul style="list-style-type: none"> • Check the light tube / if necessary exchange • Check connections • Check SRC / if necessary swap*
Lamps in continuous operation	<ul style="list-style-type: none"> • SRC defective 	<ul style="list-style-type: none"> • Check SRC / if necessary swap*
Digital display does not show everything or incorrectly	<ul style="list-style-type: none"> • Flat cable not connected • Digital display defective 	<ul style="list-style-type: none"> • Check cable • Check the display panel for damage
Time and temperature can not be adjusted	<ul style="list-style-type: none"> • Wrong switch position • Keyboard incorrectly connected or defective 	<ul style="list-style-type: none"> • Check installation of the switch • Check connections / if necessary swap*

***Exchange may only be carried out by qualified and trained service personnel.**

7. Light tubes exchange



(1)

1. Remove cassette for tube replacement

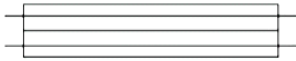

(2)

2. Remove protective grille

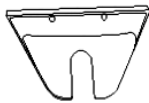

(3)

3. Remove both holder plates from the sides of the cassette



(4)

4. Remove the fixed plates from both ends of the cassette

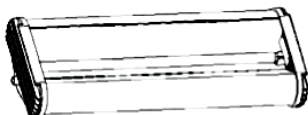

(5)

5. Disconnect cable connections and screws.
Subsequently the arc tube can be exchanged



(6)

6. Follow the reverse order of assembling the cassette

8. Circuit diagram

